

#500 PANTHER[®] FLOOR STRIPPER

INSTRUCTION MANUAL



READ MANUAL BEFORE OPERATING MACHINE



National
Flooring Equipment, Inc.



9250 XYLON AVENUE NORTH • MINNEAPOLIS, MN 55445 • U.S.A.
800-245-0267 • 763-535-8206 • FAX 763-535-8255 • FAX 800-648-7124
WEB SITE: www.nationalequipment.com • E-MAIL: info@nationalequipment.com

TABLE OF CONTENTS

■ Table of Contents	2
■ Rules for Safe Operation.....	3-6
A. Grounding	5
B. Extension Cords	6
■ General Operation.....	7-10
A. Specifications	7
B. Assembly	7-8
C. Wheel Adjustment	8
D. Handle Adjustment	9
E. Machine Operation	9
F. Machine Start Up Procedure	9
G. User General Information.....	9-10
H. Transportation	10
■ Blades	11-16
A. Blade Changing.....	11
B. Blade Setting	11-12
C. Types of Tearouts.....	13-14
D. Blade Diagram.....	15
E. Blade Chart	16
■ Maintenance	17
A. Maintaining Equipment	17
B. Cleaning	17
C. Repairs	17
■ Procedures	18
A. Lubrication.....	18
■ Troubleshooting	19
■ Complete Parts List.....	20-21
■ Part Numbers and Diagrams.....	22-23
■ Labels	24
■ Guarantee.....	25
■ Return Sheet	26
■ Blade Order Form.....	

RULES FOR SAFE OPERATION

READ AND SAVE ALL INSTRUCTIONS FOR FUTURE USE. Before use, be sure everyone operating this equipment reads and understands this manual as well as any labels packaged with or attached to the tool.

1. **KNOW YOUR POWER TOOL:** Read this manual carefully to learn your equipment applications and limitations as well as potential hazards associated with this type of equipment.

▲ WARNING: When using electric tools, always follow basic safety precautions to reduce the risk of electric shock and personal injury.

2. **GROUND YOUR TOOL:** Unless your tool is double insulated, it should be grounded. *See Grounding.*
3. **AVOID DANGEROUS ENVIRONMENTS:** Do not use in rain, damp or wet locations, or in the presence of explosive atmospheres (gaseous fumes, dust or flammable materials). Remove materials or debris that may be ignited by sparks.
4. **KEEP WORK AREA CLEAN AND WELL LIT:** Cluttered, dark work areas invite accidents.
5. **DRESS PROPERLY:** Do not wear loose clothing. These may be caught in moving parts. When working outdoors, wear rubber gloves and insulated non-skid footwear. Keep hands and gloves away from moving parts.
6. **USE SAFETY EQUIPMENT:** Everyone in the work area should wear safety goggles or glasses complying with current safety standards. Wear hearing protection during extended use and a dust mask for dusty operations. Hard hats, face shields, safety shoes, etc. should be worn when specified or necessary.
7. **KEEP BYSTANDERS AWAY:** Children and bystanders should be kept at a safe distance from the work area to avoid distracting the operator and contacting the tool or extension cord. Operator should be aware of who is around them and their proximity.
8. **PROTECT OTHERS IN THE WORK AREA:** Provide barriers or shields as needed, to protect others from debris.
9. **USE PROPER ACCESSORIES:** Using accessories that are not recommended may be hazardous. Be sure accessories are properly installed and maintained. Do not delete a guard or other safety device when installing an accessory or attachment.
10. **CHECK FOR DAMAGED PARTS:** Inspect guards and other parts before use. Check for misalignment, binding of moving parts, improper mounting, broken parts and any other conditions that may affect operation. If abnormal noise or vibration occurs, turn the tool off immediately and have the problem corrected before further use. Do not use a damaged tool. Tag damaged tools "DO NOT USE" until repaired. A guard or other damaged parts should be properly repaired or replaced. For all repairs, insist on only identical National replacement parts.
11. **REMOVE ALL ADJUSTING KEYS AND WRENCHES:** Make a habit of checking that the adjusting keys, wrenches, etc. are removed from the tool before turning it on.
12. **GUARD AGAINST ELECTRIC SHOCK:** Prevent body contact with grounded surfaces such as pipes, radiators, ranges and refrigerators. When making cuts, always check the work area for hidden wires or pipes. Hold your tool by insulated nonmetal grasping surfaces. Use a Ground Fault Circuit Interrupter (GFCI) to reduce shock hazards.
13. **AVOID ACCIDENTAL STARTING:** Be sure your tool is turned off before plugging it in. Do not use a tool if the power switch does not turn the tool on and off.

RULES FOR SAFE OPERATION

14. **DO NOT FORCE TOOL:** Your tool will perform best at the rate for which it was designed. Excessive force only causes operator fatigue, increased wear and reduced control.
15. **KEEP HANDS AWAY FROM ALL CUTTING EDGES AND MOVING PARTS.**
16. **WEAR GLOVES WHEN CHANGING BLADES.**
17. **DO NOT ABUSE CORD:** Never unplug by yanking the cord from the outlet. Pull plug rather than cord to reduce the risk of damage. Keep the cord away from heat, oil, sharp objects, cutting edges and moving parts.
18. **DO NOT OVERREACH. MAINTAIN CONTROL:** Keep proper footing and balance at all times. Maintain a firm grip.
19. **STAY ALERT:** Watch what you are doing, and use common sense. Do not use a tool when you are tired, distracted or under the influence of drugs, alcohol or any medication causing decreased control.
20. **STARTING MACHINE:** On/off switch must be in off position before connecting to power source.
21. **UNPLUG TOOL:** When it is not in use, unplug tool before changing accessories or performing recommended maintenance.
22. **MAINTAIN TOOLS CAREFULLY:** Keep handles dry, clean and free from oil and grease. Keep cutting edges sharp and clean. Follow instructions for lubricating and changing accessories. Periodically inspect tool cords and extension cords for damage. Have damaged parts repaired or replaced.
23. **STORE IDLE TOOLS:** When not in use, store your tool in a dry, secured place. Keep out of reach of children.
24. **MAINTAIN LABELS AND NAMEPLATES:** These carry important information. If unreadable or missing, contact National for a free replacement.
25. **MACHINE IS HEAVY, DO NOT DROP:** Counter weights are heavy. Take caution when removing or reassembling.

 **WARNING:** Exposure to dust may cause respiratory ailments. Use approved NIOSH or OSHA respirators, safety glasses or face shields, gloves and protective clothing. Provide adequate ventilation to eliminate dust, or to maintain dust level below the Threshold Limit Value for nuisance dust as classified by OSHA.

RULES FOR SAFE OPERATION

GROUNDING

⚠ WARNING: Improperly connecting the grounding wire can result in the risk of electric shock. Check with a qualified electrician if you are in doubt as to whether the outlet is properly grounded. Do not modify the plug provided with the tool. Never remove the grounding prong from the plug. Do not use the tool if the cord or plug is damaged. If the plug will not fit the outlet, have a proper outlet installed by a qualified electrician.

⚠ WARNING: Electrical cords can be hazardous. Misuse can result in fire or death by electrical shock. Read carefully and follow all directions.

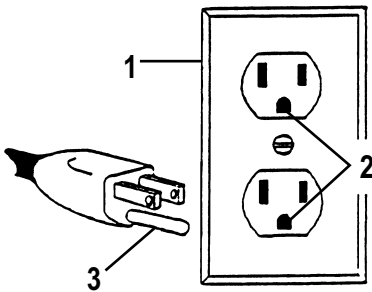

Figure A

1. Cover of grounded outlet box
2. Outlet ground
3. Grounding prong
4. Temporary adapter
5. Screw
6. Green grounding ear

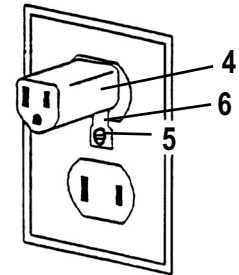

Figure B

GROUNDING TOOLS: TOOLS WITH THREE PRONG PLUGS

Tools marked "Grounding Required" have a three wire cord and three prong grounding plug. The plug must be connected to a properly grounded outlet. See *Figure A*. If the tool should electrically malfunction or break down, grounding provides a low resistance path to carry electricity away from the user, reducing the risk of electric shock.

The grounding prong in the plug is connected through the green wire inside the cord to the grounding system in the tool. The green wire in the cord must be the only wire connected to the tool's grounding system and must never be attached to an electrically "live" terminal.

Your tool must be plugged into an appropriate outlet, properly installed and grounded in accordance with all codes and ordinances. The plug and outlet should look like those in *Figure A*.

Figure B illustrates a temporary adapter available for connecting grounded plugs (*Figure A*) to two prong outlets. The green rigid ear or lug extending from the adapter must be connected to a permanent ground such as a properly grounded outlet box or receptacle. Simply remove the center screw from the outlet, insert the adapter and reattach the screw through the green grounding ear to the outlet. If in doubt of proper grounding, call a qualified electrician. A temporary adapter should only be used until a properly grounded outlet can be installed by a qualified electrician. The Canadian Electrical Code prohibits the use of temporary adapters.

RULES FOR SAFE OPERATION

EXTENSION CORDS

⚠ WARNING: Electrical cords can be hazardous. Misuse can result in fire or death by electrical shock. Read carefully and follow all directions.

Grounded tools require a three wire extension cord. Double insulated tools can use either a two or three wire extension cord. As the distance from the supply outlet increases, you must use a heavier gauge extension cord. Using extension cords with inadequately sized wire causes a serious drop in voltage, resulting in loss of power and possible tool damage.

The smaller the gauge number of the wire, the greater the capacity of the cord. For example, a 14 gauge cord can carry a higher current than a 16 gauge cord. When using more than one extension cord to make up the total length, be sure each cord contains at least the minimum wire size required. If you are using one extension cord for more than one tool, add the nameplate amperes and use the sum to determine the required minimum wire size.

GUIDELINES FOR USING EXTENSION CORDS

- If you are using an extension cord outdoors, make sure it is marked with the suffix “W-A” (“W” in Canada) to indicate that it is acceptable for outdoor use.
- Be sure your extension cord is properly wired and in good electrical condition. Always replace a damaged extension cord or have it repaired by a qualified person before using it.
- Protect your extension cords from sharp objects, excessive heat and damp or wet areas.
- Keep away from water. Do not use if wet. 
- Inspect thoroughly before each use. **DO NOT USE IF DAMAGED.**
- Make sure equipment is OFF before connecting cord outlet.
- FULLY INSERT plug into outlet.
- Do not remove, bend or modify any metal prongs or pins of cord.
- Do not use excessive force to make connections.
- Do not connect a three prong plug to a two-hole cord.
- Avoid overheating. Uncoil cord and do not cover it with any material.
- Do not walk on cord.
- Do not drive, drag or place objects over cord.

READ AND SAVE ALL INSTRUCTIONS FOR FUTURE REFERENCE.

GENERAL OPERATION

SPECIFICATIONS

SPECIFICATIONS	#500
Length:	24"
Width:	13.5"
Height w/Handle:	44"
Height w/o Handle:	21"
Weight (machine only):	97 lbs.
Speed:	Manual
MOTOR INFORMATION	
RPM:	1725
Volts:	110
HP:	1
Amps-Full Load:	Under 10
Continuous Duty	

ASSEMBLY

THE PANTHER COMES DISASSEMBLED.

1. Slide switch onto handle leg with switch to the inside of handle (See Figure A).
2. Loosen the top two T-bolts on the handle frame.
3. Insert handle into handle frame (See Figure A) and adjust to desired height
4. Retighten T-bolts on the handle frame.
5. Slide switch upward.
6. Tighten switch box thumbscrew.
7. Loosen T-bolt on adjustment T-bar (See Figure B).
8. Pull up on handle to raise base of machine, engaging wheels to floor surface (See Figure C).
9. Securely Retighten T-bolt on adjustment T-bar.

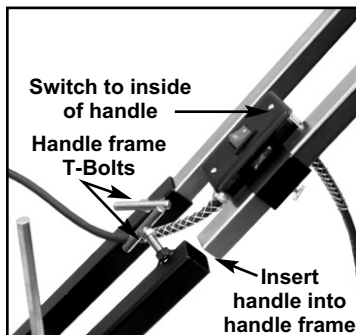

Figure A

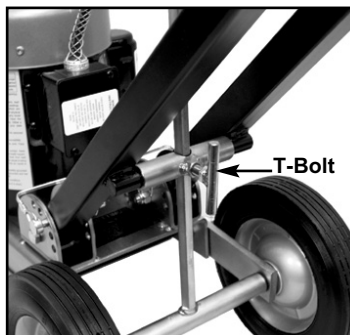

Figure B

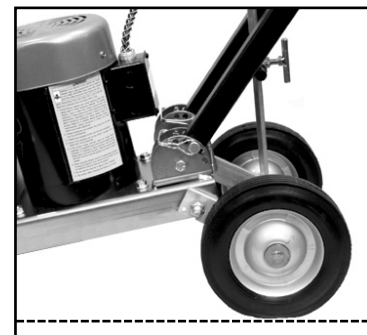

Figure C

GENERAL OPERATION

ASSEMBLY (continued)

FOR SHIPPING, WHEEL ADJUSTMENT PINS ARE NOT INSERTED CORRECTLY THROUGH HANDLE FRAME.

1. Remove handle adjustment pins (See Figure A). It may be necessary to maneuver handle so it is not touching the handle adjustment pins. OR, lay machine onto side (See Figure B).
2. Adjust handle to proper angle (center hole is the most common).
3. Insert handle adjustment pins into desired hole (See Figure C) and secure.

⚠ WARNING: Do not operate machine around excessive moisture areas, such as abatement work and flooded pool areas without GFI wall plug (stock #530 Circuit Guard). Failure to do so could cause damage in machine or injury to operator.



Figure A



Figure B



Figure C

WHEEL ADJUSTMENT

Adjusting wheel angle will change the blade angle to the floor. A steep wheel angle is recommended on hard tear-outs such as tile over concrete (See Figure D). A low wheel angle is recommended on vinyl tear-outs and plywood floors (See Figure E).

1. Loosen T-Bolt on adjustment T-bar.
2. Adjust wheels (by handle) to preferred angle.
3. Securely tighten T-bolt on adjustment T-bar.

NOTE: Adjustment by trial at the beginning of a job will give optimum performance.

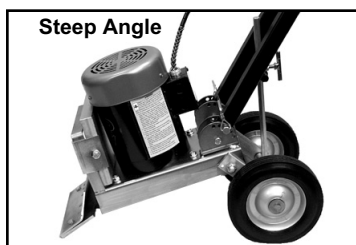

Figure D

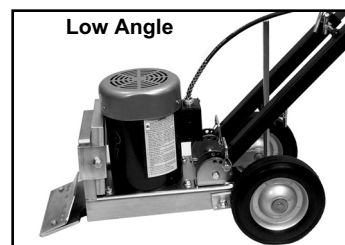

Figure E

GENERAL OPERATION

HANDLE ADJUSTMENT

AFTER THE PROPER WHEEL ADJUSTMENT IS ACHIEVED, ADJUST HANDLE BY EITHER A OR B:

- A. Removing handle adjustment pins, adjust handle to proper angle and reinsert handle adjustment pins.
- B. Lay machine on side, remove handle adjustment pins, adjust handle to proper angle and reinsert handle adjustment pins.

No matter what the wheel angle is set at, the handle should be adjusted to the "belt-line" of the operator or to what the operator is comfortable with (See Figure A).

- Low setting works best on soft sub floors, plywood, luan, particleboard and wafer board.
- Higher setting works best on direct glued down carpet, vinyl or tile on concrete.



Figure A

NOTE: Adjustment by trail at the beginning of a job will give optimum performance.

MACHINE OPERATION

A well maintained machine is a productive machine. If not properly maintained, it could be unsafe and could break down. A scheduled maintenance program should insure a long system life and a safe work environment.

MACHINE START PROCEDURE

TO RUN MACHINE:

1. Machine **MUST** be off before plugging machine into power source.
2. Plug machine into extension cord and/or outlet.
3. Turn switch to on.

USER GENERAL INFORMATION

1. Always wear eye protection
2. Keep flammable and fragile objects away from this tool.
3. Always check nuts and bolt to make sure they are tight.
4. Always use the tool with proper voltage specified in the machines nameplate.
5. Do not operate around water or wet conditions without use of GFI on cord (stock #530 Circuit Guard).
6. Use properly grounded cord and receptacle.
7. Unplug from power before servicing or changing blades.
8. Use 12-3 or heavier wire cord, not exceeding 50 feet in length.
9. Do not force machine.
10. Do not alter machine.
11. Keep wheels free from debris.

GENERAL OPERATION

USER GENERAL INFORMATION (continued)

12. Dropping machine onto cutting head could cause damage to blade holder and cause undue wear on bearing surface.
13. Removable handle and front weight makes machine portable (fits in a trunk of a car).
14. Do Not leave machine unattended while machine is running.

TRANSPORTATION

Always remove counterweight and blades before loading or unloading.

Machine breaks down for easy transportation:

- Handle removes
- Handle and/or wheel angle can be lowered

⚠ WARNING: Keep hands and feet out from under machine.

BLADES

BLADE CHANGING

⚠ CAUTION: Blades are sharp. Handle with care. Failure to do so could cause bodily injury.



- Dull blades greatly reduce cutting ability. Re-sharpen or replace as needed.
 - Proper blade size and placement per job type greatly affects performance.
 - Disconnect electrical power first.
 - Do not lean machine back onto handle.
 - Always wear gloves when changing blades to protect fingers and hands.
1. Place a block under front of machine as shown in diagram, raising blade holder (See Figure A).

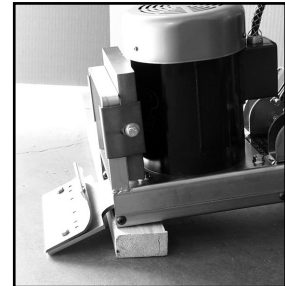

Figure A

2. Use extended socket wrench that comes with Panther or a socket wrench with at least a 3" extension to keep hand safely away from the sharp edge of the blade.
 3. Loosen two blade cover bolts with extended wrench. It is not necessary to remove bolts.
 4. Place blade into cutting head, sliding all the way back to the bolts. If the blade is wider than the cutting head, center blade to head. If blade is smaller than the cutting head, first pass blade should be mounted in center of the cutting head. After first pass is made, blade can be offset in head to allow wheels to keep even contact with the floor and allow easy access to the wall. Blades of longer width can be mounted in either holes or slots or put in front of blade cover bolts.
 5. Securely tighten bolts.
- Blades are extremely sharp, use caution.
 - A new sharp blade being used on wood or alike sub floors may work better when slightly dulled to avoid digging or gouging.
 - Use National Flooring Equipment's replacement blades.

BLADE SETTING

- Dull blades greatly reduce cutting ability. Re-sharpen or replace as needed.
- Proper blade size and placement, depending on material and sub-floor type, affects performance.
- The harder a job comes up, for best results, use a smaller blade.
- Start with a narrow blade, then increase blade size to optimize cutting pass. Narrower blades work easier than wider blades and usually clean the floor better. Wider is not always better or faster.
- Normally bevel on blade is up for concrete. Bevel down for wood or soft sub-floors.



BLADES

BLADE SETTING (continued)

- Wood or wood like floors: pound down or remove any nails or metal obstruction to avoid blade damage.
- Blades can be offset in cutting head for easier access to toe kicks or removal along the wall (See Figure A).
- Sheet vinyl, solid vinyl, rubber tile, urethane or PVC sheet roofing, will need to be scored for best removal results. Nationals #584 Scoring Tool. See Figure B.
- On direct glued down carpet, the carpet should be scored to blade width for optimum ease of use (See Figure C).
- Self scoring blades are available in a number of sizes. These blades eliminate the need for pre-scoring material. The 5" x 6" blade is recommended. Do not go larger than a 3" x 12" blade. Depending upon the type of material being removed and the sharpness of the blade and scoring wings, the self scoring blades may make it harder to control the machine.
- **Keep scoring wings sharp at all times.**
- Keep in mind, narrow width blades will make a cleaner floor surface.
- When working over plywood sub-floor, try to work in the direction of the wood grain.
- When working over concrete, beware of expansion joints and sub-floor mounted receptacles.
- Proper blade size and placement, depending on material and sub-floor type, greatly affects performance. (The harder a job comes up, the smaller the blade for ease of use.)
- **KEEP BLADES SHARP!**
- Dull blades greatly affect the performance of the machine.
- Keep your work area clean and clear of debris.
- After you have removed a portion of material, remove it out of the way. This will give the machine maximum performance and help to keep the work area safe.



Figure B

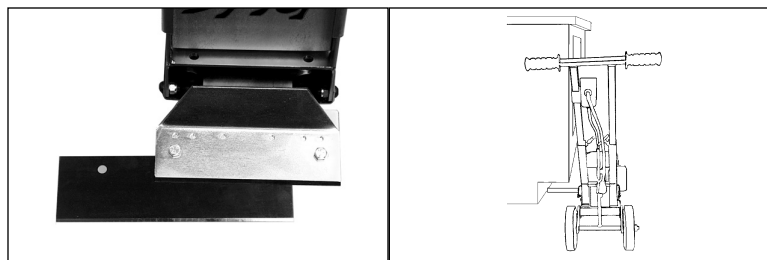

Figure A

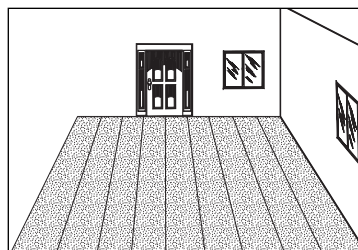

Figure C

BLADES

TYPES OF TEAROUTS

REMOVAL MATERIALS

⚠ WARNING: Never remove flooring containing asbestos without fully understanding proper state and federal procedures and guidelines.

- **VCT TILE:** Never use a blade wider than the size of the tile being removed (See Figure A). If goods being removed still do not come up clean or machine jumps on top of goods, reduce blade size to a smaller blade until proper blade size is found or use a smaller portion of the blade. The most common blade sizes when removing tile are the 4" x 6" or the 5" x 6".
- **PURE VINYL RUBBER TILE:** Goods will need to be scored down to 10 to 12 inches for proper removal (See Figure B). Self scoring blades can be used with some materials. A 10" blade is recommended for this product, but determine what size blade works best.
- **DIRECT GLUED CARPET:** Can be done with either self scoring blades (Figure D) or pre-score carpet to blade width prior to stripping with #584 Scoring Tool. Pre-scored carpet makes machine easier to control and blades stay sharper longer. Blades up to 16" wide can be used. Normally 12" to 14" blades are used on direct glued carpet, secondary backed, unitary, double glued, vinyl foam, urethane foam. Latex foams come up easily with a 16" blade.
- **HARD TO REMOVE SURFACES:** Ripper teeth can be used on hard to remove goods (Hardwood & VCT) (See Figure C).



Figure A



Figure B

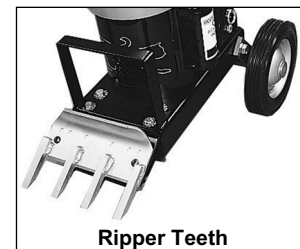

Ripper Teeth



Figure C



BLADES

TYPES OF TEAROUTS (continued)

SUBFLOOR SURFACES

- **WOOD:** When working over plywood sub-flooring, try to run machine in the same direction as the grain in the wood. Blade in most cases should be bevel down. On solid wood floors, like plank, run in the same direction as the plank, not cross grain or cross plank. Removing the front counter weight will help on all soft surfaces.
- **CONCRETE:** When working on a concrete slab, normal blade position is bevel up for best performance, especially when cleaning adhesive. On occasion, bevel down gives better blade life. Test each job for best performance.  **BEVEL DOWN**
- **GIBCRETE AND SOFT Poured FLOORING:** Usually requires blade bevel down to create a better wearing surface, although bevel up may work if front counter weight is removed.  **BEVEL UP**

⚠ CAUTION: Beware of expansion joints and floor mounted receptacles or other obstacles in the floor.

EYE PROTECTION SHOULD BE USED AT ALL TIMES.

- **GLUED HARD WOOD FLOORING:** A 10" blade is recommended for regular adhesive, a 6" blade for epoxy. For proper removal of hardwood flooring (parkay laminated, plank laminated, plank solid) flooring must be scored to blade width. This is done by using a circular saw set at a depth of 99% of the thickness of the board, just missing the subfloor surface when on concrete (See Figure A). A chalk line for scoring lines can be used across the floor the width of the blade (See Figure B). A ripping guide attached to the saw can be used to eliminate chalk line marks. Open an area large enough to fit machine or start from a doorway. It is important to keep all debris cleaned up for maximum performance of machine. True Parkay flooring scoring is not necessary. It will come up in small pieces.

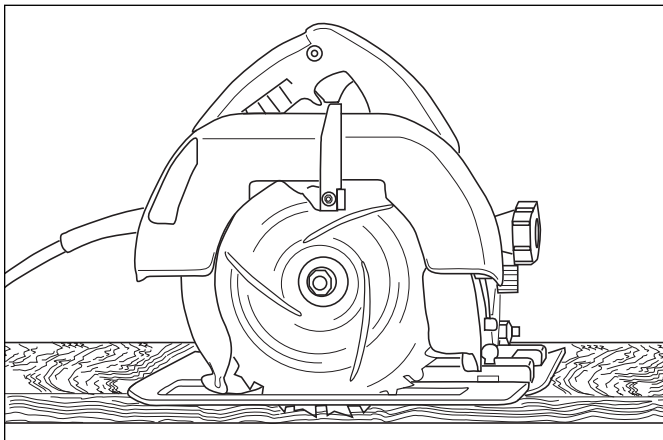

Figure A

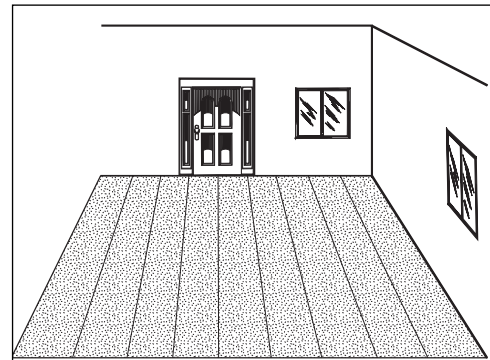
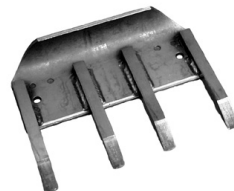
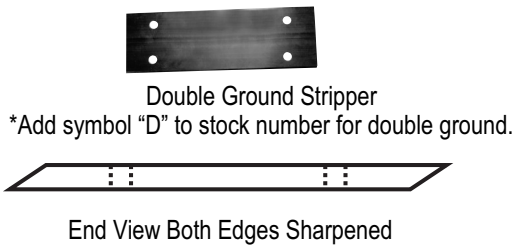
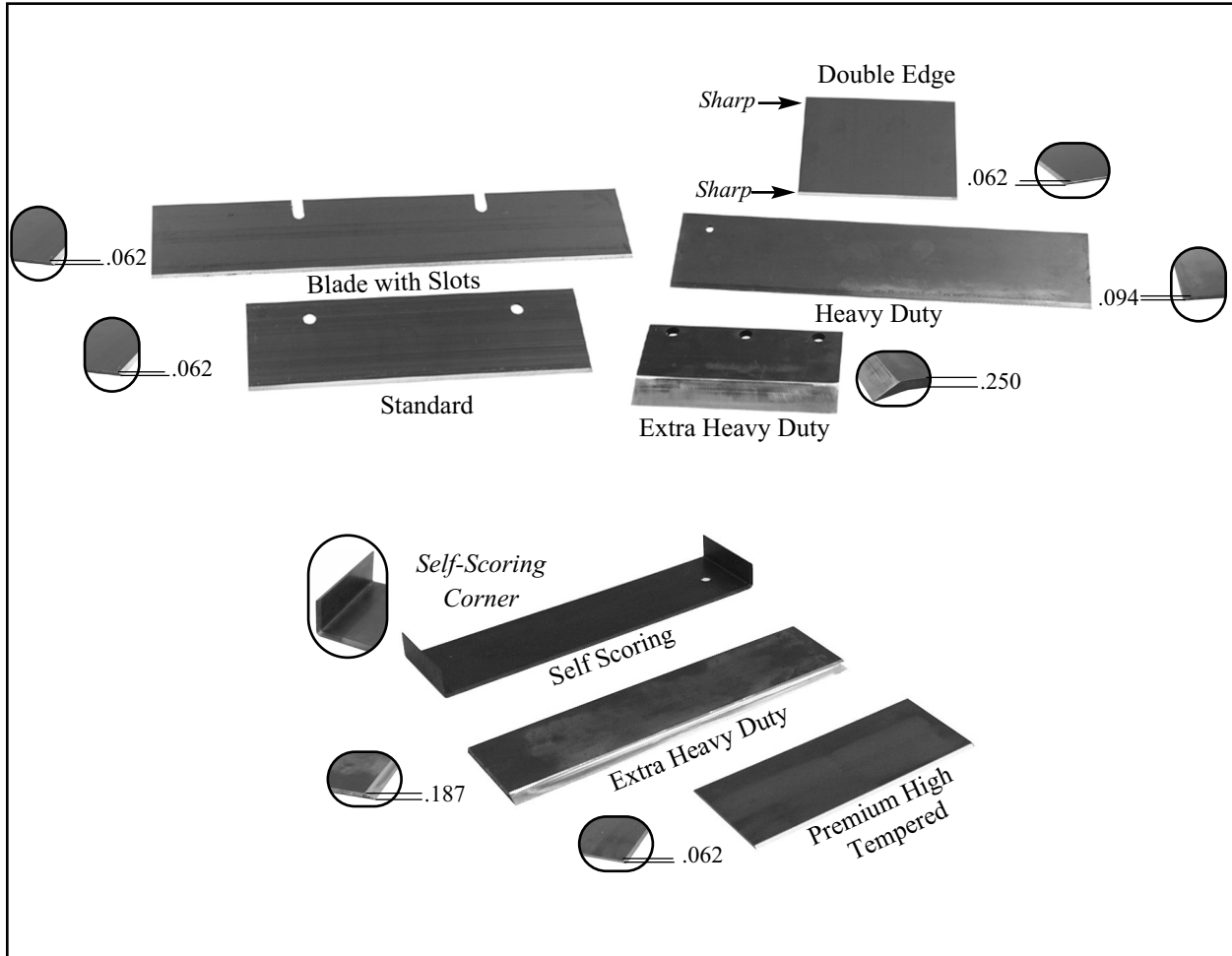

Figure B

BLADES

BLADE DIAGRAM



#502 Ripper Teeth
For difficult surfaces;
ceramic, hardwood, heavy
tile, etc.

⚠ WARNING: Never remove flooring containing asbestos without fully understanding proper state and federal procedures and guidelines for removal of these products. Laws are different from state to state.

BLADES

Part #	Description	Application	Thickness
#130-S	3" x 10" Blade with slots	glued down carpet, tile or resilient	.062
#130-D	#130 Blade with both edges sharpened	carpet, tile or resilient on wood & concrete floors	.062
#131-S	3" x 16" Blade with slots	glued down rubber carpet, floor accumulation	.062
#135	5" x 16" Blade	Rubber back carpet on wood or concrete floors, excellent for cleanup and longer durability.	.062
#147	4" x 6" Blade	tile or linoleum on concrete floors	.062
#147-D	#147 Blade with both edges sharpened	tile or linoleum on concrete floors	.062
#148	5" x 6" Blade	tile or linoleum on wood floors	.062
#148-D	#148 Blade with both edges sharpened	tile or linoleum on wood floors	.062
#502	Panther [®] Ripper Teeth	Difficult surfaces: ceramic, hardwood, heavy tile etc.	
#6255-BU	4" x 6" Self Scoring Blade - Bevel Up	Works on attached cushion, Unitary or secondary backing, vinyl backing, soft to medium Pvc, linoleum, carpet tiles, soft cork, Enhancer and Uniband hot melts.	.062
#6257-BU	3" x 9" Self Scoring Blade - Bevel Up		.062
#6281	3" x 8" Heavy Duty Blade	A heavy duty blade that still gives a little flex. Made with Nationals proven blade hardening process, these blades will stay sharper longer with better overall performance than any other blade on the market. Works on Vct, Vat, wood, tile, rubber epoxy, thin-set, elastomeric coatings, scraping thin-set, glued ceramic.	.094
#6282	3" x 14" Heavy Duty Blade		.094
#6284	3" x 12" Heavy Duty Blade		.094
#6285	3" x 6" Heavy Duty Blade		.094
#6286	3" x 10" Heavy Duty Blade		.094
#6290	3" x 6" Extra Heavy Duty Blade		Extremely hard, high abrasion alloy for tough tear-up situations. Vct, Vat, wood, tile, thin ceramic, re-scraping thin-set, all carpets, cork, elastomeric coatings, re-scraping rubber and urethane coatings. Holds the edge extremely well.
#6291	3" x 8" Extra Heavy Duty Blade	.187	
#6292	3" x 12" Extra Heavy Duty Blade	.187	
#6293	3" x 14" Extra Heavy Duty Blade	.187	
#7050-200	3" x 6" Premium High Tempered Blade	Ultra high quality spring steel is extra hard for long blade life between sharpening. Works on all glue down carpets, Vct, Vat, rubber tile, cork, re-scraping adhesive, elastomeric coatings. Great for floor accumulations.	.062
#7050-201	3" x 8" Premium High Tempered Blade		.062
#7050-202	3" x 10" Premium High Tempered Blade		.062
#7050-203	3" x 12" Premium High Tempered Blade		.062
#7050-204	3" x 14" Premium High Tempered Blade		.062
#7081	3" x 10" Increased Angle Blade	Mainly used for VCT, but can be used on most other applications. Supplies more of an angle when angle is needed. Prevents machine from jumping off material.	.062
#7083	3" x 8" Increased Angle Blade		.062

MAINTENANCE

⚠ WARNING: To reduce the risk of injury, always unplug equipment from power source before performing any maintenance. Never disassemble the tool or try to do any rewiring on the tool's electrical system. Failure to do so could cause damage to machine or serious injury. Contact National for ALL repairs.

MAINTAINING EQUIPMENT

Keep equipment in good repair by adopting a regular maintenance program. Before use, examine the general condition of equipment. Inspect guards, switches, tool cord set and extension cord for damage. Check for loose screws, misalignment, binding of moving parts, improper mounting, broken parts and any other condition that may affect its safe operation. If abnormal noise or vibration occurs, turn the tool off immediately and have the problem corrected before further use. Do not use a damaged tool. Tag damaged tools "DO NOT USE" until repaired. See Repairs.

- Mechanical inspection
- Cleaning (pulleys, spindles, bearings, housing, etc.)
- Electrical inspection (switch, cord, plugs, etc.)
- Testing to assure proper mechanical and electrical operation
- Check nuts on shock absorbers and bottom plate for tightness
- Check screws on bottom bearing for tightness
- Check all screws and fittings for a tight and secure fit
- Keep a sharp blade in machine for optimum performance

CLEANING

Clean dust and debris from vents. Keep the equipment's handle clean, dry and free of oil or grease. Use only mild soap and a damp cloth to clean since certain cleaning agents and solvents are harmful to plastics and other insulated parts. Some of these include: gasoline, turpentine, lacquer thinner, paint

⚠ WARNING: To reduce the risk of injury, electric shock and damage to the tool, never immerse your tool in liquid or allow a liquid to flow inside the tool.

thinner, chlorinated cleaning solvents, ammonia and household detergents containing ammonia. Never use flammable or combustible solvents around tools.

REPAIRS

If your tool is damaged, contact National for a return authorization number and return the entire tool.

- Shipments are not accepted without a return authorization number.
- COD or freight collect shipments will not be accepted.

PROCEDURE

LUBRICATION

- A. Bearing Block
- B. Head Pin & Bearing
- C. Eccentric & Bearing
- D. Body Frame
- E. Cutting Head
- F. Bearing Block Bolt

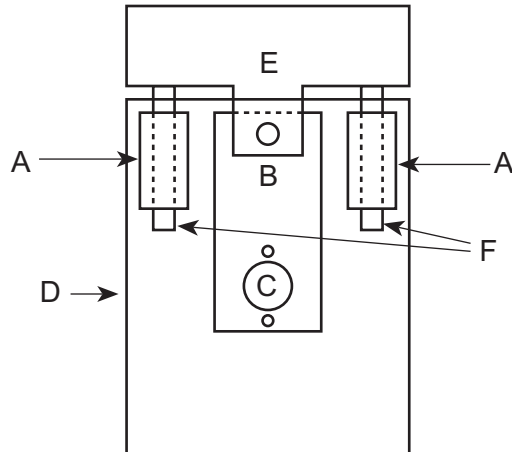

- Lubricate parts A, B, & C. Failure to do so will decrease overall bearing life.
- Minimum of every 100 hours of operation, bearing wear should be checked. This is done by tipping machine upside down, and shaking cutting head up and down away from frame. If noticeable movement is detected, bearing block readjustment or replacement is necessary.

Loosen bolts for A to finger tight, using large screwdriver or small pry bar. Apply pressure between frame wall (D) and bearing block (A). While pressure is applied, retighten. If excessive noise or side to side movement remains, bearing should be replaced. Make sure you only loosen one bearing block at a time to retain hand alignment. If head alignment is out, loosen both bearing blocks (A) to finger tight, align cutting head (E) to frame front (D) so there is even distance on both sides. Retighten bearing block. Head bearings can be checked by manually moving cutting head in and out. If excessive movement or noise occurs while running, head bearing (B) needs to be replaced. Head must be removed from machine and drive pin (B) press fit removed to replace this bearing.

<u>PART #</u>	<u>DESCRIPTION</u>	<u>PART #</u>	<u>DESCRIPTION</u>
500-40	Drive Head	500-44	Bearing Block Bolt 3/4 x 3-3/4
500-42	Drive Head Pin	500-46	Flange Bearing with Fastener
500-43	Bearing Block with Bushing	62104	Eccentric

TROUBLESHOOTING

THERE IS NO POWER

1. Inspect electrical cord.

MOTOR NOISE

1. Make sure fan guard is not bent.

RATTLING

1. Tighten loose nuts and bolts.

MACHINE IS HARD TO HANDLE

1. Remove the counterweight.
2. Change to a smaller blade.
3. Sharpen blade.

BLOWS FUSES OR CIRCUIT BREAKERS

1. Check and/or change attached power cord. Use a 12 gauge cord, 50' or less.
2. Move to a different outlet or a better circuit.

COMPLETE PARTS LIST

PART #	DESCRIPTION
500-10	COVER PLATE ONLY
500-10A	SWITCH ONLY
500-12	WIRE W/MOLDED PLUG
500-13	SWITCH BOX ONLY
500-14	WIRE STRAIN RELIEF
500-15	HANDLE GRIPS ONLY (EACH)
500-16L	HANDLE SUPPORT LEGS (LEFT)
500-16R	HANDLE SUPPORT LEGS (RIGHT)
500-19	BLADE COVER
500-25	WHEEL LEG (2)
500-29	WHEEL (2)
500-30	WHEEL AXLE
500-30A	O RING (2) (NOT SHOWN)
500-32	ADJUSTMENT T BAR
500-33	ADJUSTMENT T BAR SLEEVE
500-37	BASE WELDMENT
500-40	DRIVE HEAD
500-41	DRIVE HEAD RETAINER CLIP (2 PER UNIT)
500-42	DRIVE HEAD PIN
500-43	BEARING BLOCK WITH BUSHING
500-45	DRIVE BAR WITH BUSHING
500-45-1	BUSHING ONLY FOR DRIVE BAR (NOT SHOWN)
500-54	BLADE COVER WRENCH
503	WEIGHT ATTACHMENT
503-1	WEIGHT CLIP W/BOLT (NOT SHOWN)
6280-178	STRAIN RELIEF
62104	ECCENTRIC
62112	SHAFT COLLAR WITH SET SCREW (2)
62140	UPPER HANDLE WITH GRIPS
62151	SWITCH ASSEMBLY WIRED COMPLETE
62180	MOTOR FAN COVER
62181	MOTOR FAN (NOT SHOWN)
62182	CAPACITOR COVER
62183	CAPACITOR (NOT SHOWN)
62190	CONDUIT BOX ONLY
62191	CONDUIT BOX COVER ONLY (NOT SHOWN)
62192	CONDUIT BOX COVER SCREW ONLY (NOT SHOWN)
71118	FLANGE BEARING ONLY 1" SB206-16
71118-1	FLANGE BEARING WITH FASTENER 1"(NOT SHOWN)
72352	1 HP MOTOR
73028	1/4-20 THUMB SCREW
73205	3/8-16 X 3/4 HEXHEAD BOLT (4)
73206	3/8-16 X 1-1/4 HEXHEAD BOLT
73207	3/8-16 NYLON LOCK NUT (HANDLE SUPPORT) (2)
73210	3/8 INTERNAL/EXTERNAL LOCK WASHER (DRIVE BAR-1, BEARING BLOCK-2)
73211	3/8-16 WIZLOCK NUT (2) (NOT SHOWN)
73215	3/8 LOCK WASHER (4)
73225	3/8-16 X 5/8 HEXHEAD BOLT (BEARING BLOCK)
73230	3/8-16 X 2-1/4 HEXHEAD BOLT (HANDLE SUPPORT) (2)
73236	3/8-16 HEX NUT
73240	3/8-16 T-BOLT (3)
73305	5/16-18 X 3/4 HEXHEAD BOLT
73330	5/16 X 2" PIN (HANDLE ADJUSTMENT) (2) - NEW STYLE
73343	1/4 X 2" PIN (HANDLE ADJUSTMENT) (2) - OLD STYLE
73402	1/2-13 NYLON LOCK NUT (WHEEL LEG) (2)
73404	1/2 FLAT WASHER (4)
73407	1/2-13 X 1-1/2 HEXHEAD BOLT (WHEEL LEG) (2)
73602	3/4-11 X 3/4 SOCKET HEAD BOLT
73902	3/16 X 3/16 X 1-3/4 KEY

COMPLETE PARTS LIST

LABELS

<u>PART #</u>	<u>DESCRIPTION</u>
L25	BLADE SETTING LABEL
L37	CAUTION SHARP BLADES LABEL
L38	DISCONNECT POWER LABEL
L49	CAUTION CORD LABEL
L175	NATIONAL LABEL-SMALL (NOT SHOWN)
L189	SAFE OPERATING TIPS LABEL

PART NUMBERS & DIAGRAMS

<u>PART #</u>	<u>DESCRIPTION</u>	<u>PART #</u>	<u>DESCRIPTION</u>
500-10	Cover Plate Only	500-37	Base Weldment
500-10A	Switch Only (Not Shown)	500-54	Blade Cover Wrench
500-12	Wire w/Molded Plug	503	Weight Attachment
500-13	Switch Box Only	503-1	Weight Clip w/Bolt (Not Shown)
500-14	Wire Strain Relief	6280-178	Strain Relief
500-15	Handle Grips Only (Each)	62140	Upper Handle with Grips
500-16L	Handle Support Legs (Left)	62151	Switch Assembly Wired Complete
500-16R	Handle Support Legs (Right)	73028	1/4-20 Thumb Screw
500-19	Blade Cover	73207	3/8-16 Nylock Nut (Handle Support) (2)
500-32	Adjustment T Bar	73210	3/8 Ext/Int Lock Washer (Bearing Block) (2)
500-33	Adjustment T Bar Sleeve	73225	3/8-16 x 5/8 Hexhead Bolt (Bearing Block)
		73230	3/8-16 x 2-1/4 Hexhead Bolt (Handle Support) (2)
		73240	3/8-16 T-Bolt (3)
		73308	5/16-18 x 3/4 Button Head Cap Screw
		73330	5/16 x 2" Pin (Handle Adjustment) (2) - New Style
		73343	1/4 x 2" Pin (Handle Adjustment) (2) - Old Style



PART NUMBERS & DIAGRAMS

<u>PART #</u>	<u>DESCRIPTION</u>	<u>PART #</u>	<u>DESCRIPTION</u>
500-25	Wheel Leg (2)	62190	Conduit Box Only
500-29	Wheel (2)	62191	Conduit Box Cover Only (Not Shown)
500-30	Wheel Axle	62192	Conduit Box Cover Screw Only (Not Shown)
500-30A	O Ring (2) (Not Shown)	72352	1 HP Motor
62112	Shaft Collar w/ Set Screw (2)	73402	1/2-13 Nylock Nut (2) (Wheel Leg)
62180	Motor Fan Cover	73404	1/2 Flat Washer (4)
62181	Motor Fan (Not Shown)	73407	1/2-13 x 1-1/2 Hexhead Bolt (2) (Wheel Leg)
62182	Capacitor Cover		
62183	Capacitor (Not Shown)		

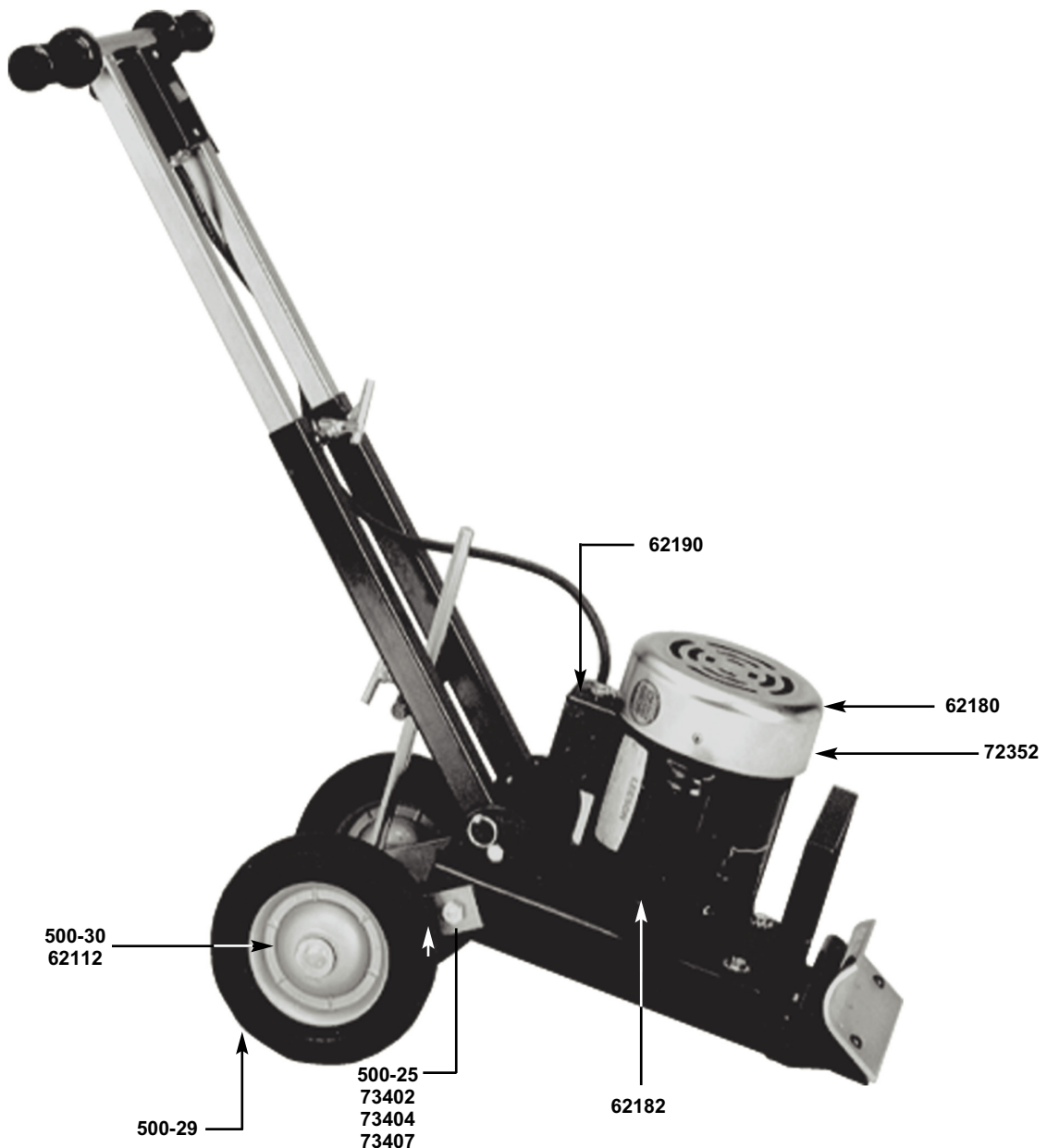

PART NUMBERS & DIAGRAMS

<u>PART #</u>	<u>DESCRIPTION</u>	<u>PART #</u>	<u>DESCRIPTION</u>
500-40	Drive Head	71118-1	Flange Bearing with Fastener 1" (Not Shown)
500-41	Drive Head Retainer Clip (2 Per Unit)	73205	3/8-16 x 3/4 Hexhead Bolt (4)
500-42	Drive Head Pin	73206	3/8-16 x 1-1/4 Hexhead Bolt
500-43	Bearing Block with Bushing	73210	3/8 Internal/External Lock Washer
500-45	Drive Bar with Bushing	73211	3/8-16 Wizlock Nut (2) (Not Shown)
500-45-1	Bushing Only for Drive Bar (Not Shown)	73215	3/8 Lock Washer (4)
62104	Eccentric	73236	3/8-16 Hex Nut
62112	Shaft Collar with Set Screw (2)	73602	3/4-11 x 3 3/4 Socket Head Bolt
71118	Flange Bearing Only 1" SB206-16	73902	3/16 x 3/16 x 1-3/4 Key

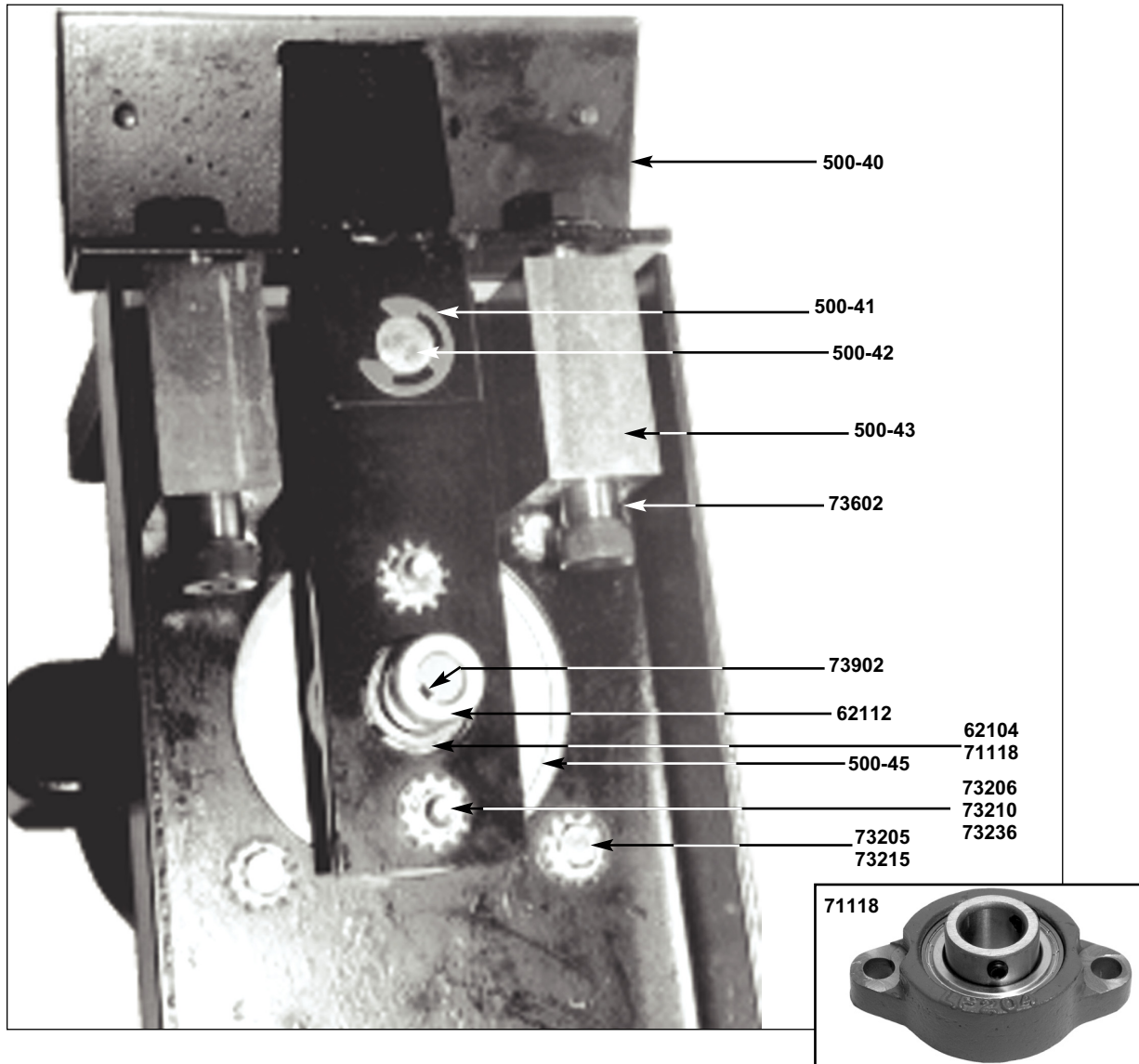

LABELS

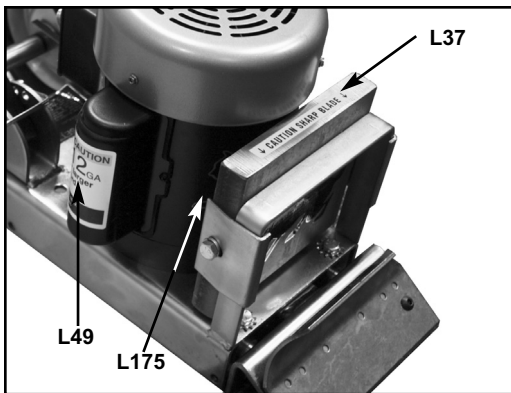
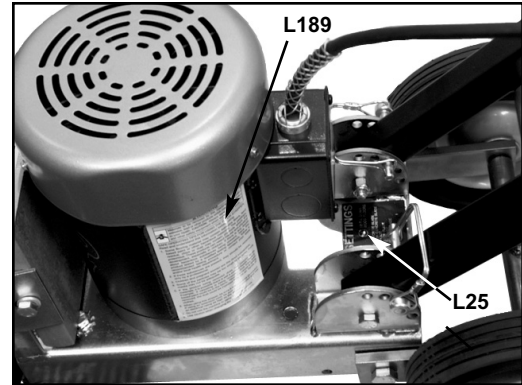
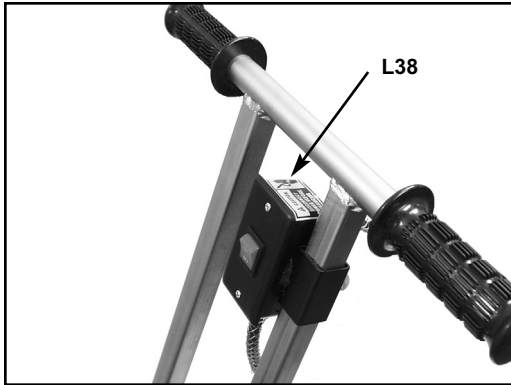

PART #	DESCRIPTION
L25	Blade Setting Label
L37	Caution Sharp Blades Label
L38	Disconnect Power Label
L49	Caution Cord Label
L175	National Label-Small
L189	Safe Operating Tips Label

GUARANTEE

National Flooring Equipment, Inc. (National) warrants to the first consumer/purchaser that this National brand product (the #500 Panther® Floor Stripper), when shipped in its original container, will be free from defective workmanship and materials and agrees that it will, at its option, either repair the defect or replace the defective product or part thereof at no charge to the purchaser for parts or labor for the period(s) set forth below.

This warranty does not apply to any appearance items of the product, to the additional excluded items set forth below, or to any product, the exterior of which has been damaged or defaced, which has been subjected to misuse, abnormal service or handling, or which has been altered or modified in design or construction.

In order to enforce the rights under this limited warranty, the purchaser should follow the steps set forth below and provide proof of purchase to National.

The limited warranty described herein is in addition to whatever implied warranties may be granted to purchasers by law. ALL IMPLIED WARRANTIES INCLUDING THE WARRANTIES OF MERCHANTABILITY AND FITNESS FOR USE ARE LIMITED TO THE PERIODS FROM THE DATE OF PURCHASE AS SET FORTH BELOW. Some states do not allow time limitations on an implied warranty, so the above limitation may not apply to you.

Neither the sales person of the seller, nor any other person, is authorized to make any other warranties other than those described herein, or to extend the duration of any warranties beyond the time period described herein on behalf of National.

The warranties described herein shall be the sole and exclusive warranties granted by National and shall be the sole and exclusive remedy available to the purchaser. Correction of defects in the manner and for the period of time described herein, shall constitute complete fulfillment of all liabilities and responsibilities of National to the purchaser with respect to the product and shall constitute full satisfaction of all claims, whether based on contract, negligence, strict liability or otherwise. In no event shall National be liable, or in any way responsible for any damage or defects in the product which were caused by repairs or attempted repairs performed by anyone other than National. Nor shall National be liable, or in any way responsible, for any incidental or consequential, economics or property damage. Some states do not allow the exclusion of incidental or consequential damages, so the above exclusion may not apply to you.

THIS WARRANTY GIVES YOU SPECIFIC LEGAL RIGHTS. YOU MAY ALSO HAVE OTHER RIGHTS WHICH VARY FROM STATE TO STATE.

WARRANTY PERIOD

The National Panther® Floor Stripper is guaranteed to be free of manufacturer defective workmanship and in quality of materials for a period of one year.

Items excluded from warranty coverage, unless found and reported defective immediately upon removal from the original shipping container and before being used by the original purchaser.

A freight damage claim must be filed with the carrier by the purchaser, the shipper cannot file the freight claim.

To obtain service contact National Flooring Equipment, Inc. toll free at 800-245-0267 for a repair authorization number. COD freight returns will not be accepted. Freight collect shipments will not be accepted. Warranty repairs must be accompanied by date of purchase receipt and a return/repair authorization number.

RETURN SHEET

Company Name _____

Contact Name _____

Telephone Number _____

Approximate Usage (hours) _____

Problems Encountered _____

Check One: Repair

Do you wish to be contacted before repairing Yes No

Return

Contact National if a loaner is needed

Return Authorization Number _____ Date _____
required, contact National

Customer Number _____
if known

Purchased From _____
if not directly from National

INTERNAL USE ONLY
Date Received _____
Unit Serial Number _____
Subject To Warranty _____

#500 BLADE ORDER FORM

Part #	Description	Thickness	Quantity
#130-S	3" x 10" Blade with Slots	.062	
#130-D	3" x 10" Double Edge Blade	.062	
#131-S	3" x 16" Blade with Slots	.062	
#135	5" x 16" Blade	.062	
#147	4" x 6" Blade	.062	
#147-D	4" x 6" Double Edge Blade	.062	
#148	5" x 6" Blade	.062	
#148-D	5" x 6" Double Edge Blade	.062	
#502	Panther® Ripper Teeth		
#6255-BU	4" x 6" Self Scoring Blade	.062	
#6257-BU	3" x 9" Self Scoring Blade	.062	
#6281	3" x 8" Heavy Duty Blade	.094	
#6282	3" x 14" Heavy Duty Blade	.094	
#6283	3" x 27" Heavy Duty Blade	.094	
#6284	3" x 12" Heavy Duty Blade	.094	
#6285	3" x 6" Heavy Duty Blade	.094	
#6286	3" x 10" Heavy Duty Blade	.094	
#6290	3" x 6" Extra Heavy Duty Blade	.187	
#6291	3" x 8" Extra Heavy Duty Blade	.187	
#6292	3" x 12" Extra Heavy Duty Blade	.187	
#6293	3" x 14" Extra Heavy Duty Blade	.187	
#7050-200	3" x 6" Premium High Temp Blade	.062	
#7050-201	3" x 8" Premium High Temp Blade	.062	
#7050-202	3" x 10" Premium High Temp Blade	.062	
#7050-203	3" x 12" Premium High Temp Blade	.062	
#7050-204	3" x 14" Premium High Temp Blade	.062	
#7081	3" x 10" Increased Angle Blade	.062	
#7083	3" x 8" Increased Angle Blade	.062	

<p>BILL TO: Attn: _____ Company: _____ Address: _____ _____ Phone: _____</p>
<p>SHIP TO: Attn: _____ Company: _____ Address: _____ _____ Phone: _____</p>

TO ORDER:

Phone: 800-245-0267 or 763-535-8206
 Fax: 800-648-7124 or 763-535-8255
 Online: www.nationalequipment.com

All orders and payment terms to be verified prior to shipping.

National Flooring Equipment, Inc.
 9250 Xylon Avenue North • Minneapolis, MN 55445
 800-245-0267 or 763-535-8206 • Fax 800-648-7124 or 763-535-8255
 Web Site: www.nationalequipment.com E-Mail: info@nationalequipment.com